

Malaysia Trade Approved.

DICKSON

**GENERAL PURPOSE
HANGING SPRING SCALE
MODEL : D H S Series**

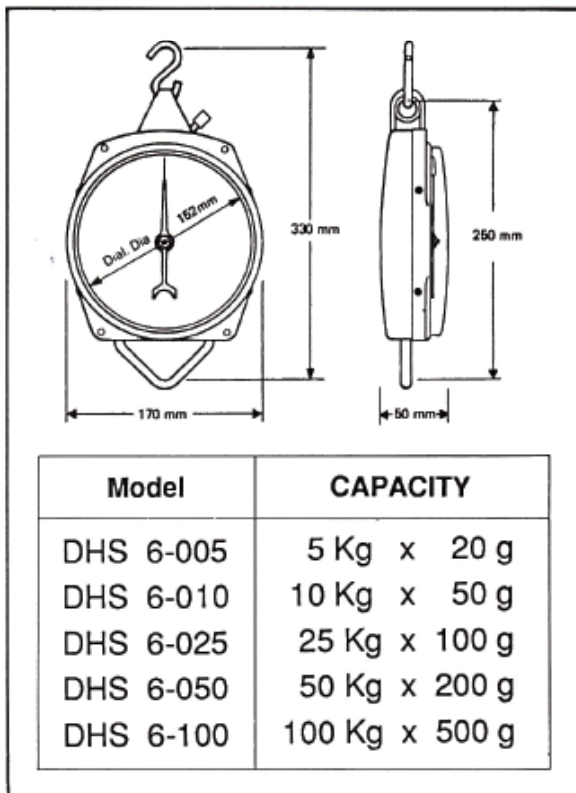
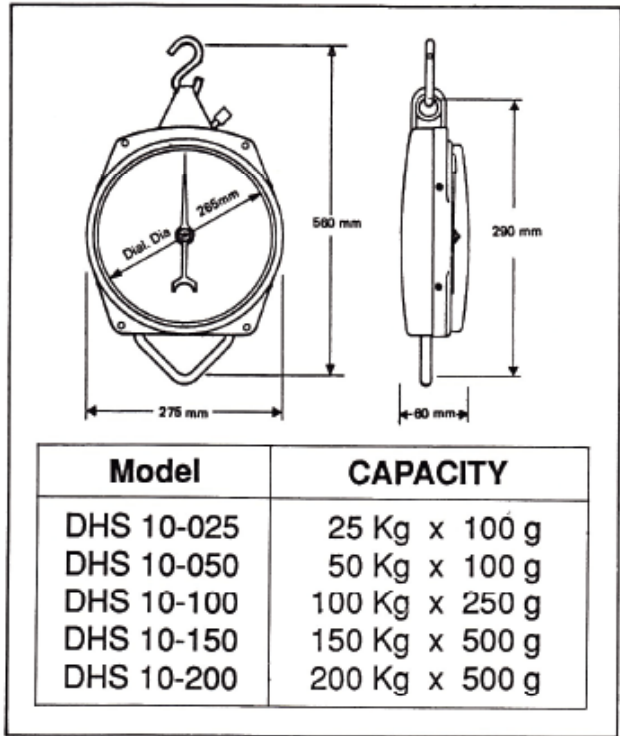
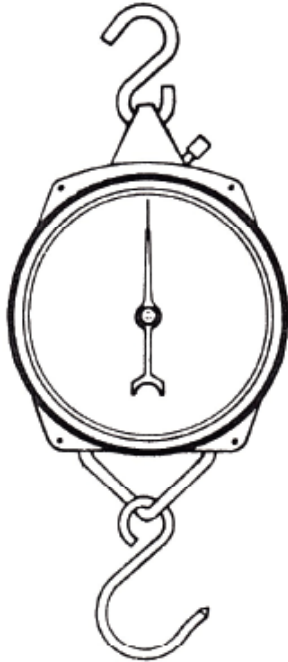

THE HEAVIEST SUSPENSION WEIGHER

FEATURES

1. Housing is of tempered aluminium die casting.(DHS-10)
2. Acrylic transparent cover is used for protecting dial.
3. Heavy duty stainless steel hanging hook; firm & durable construction.
4. Large scale dial. 10 inches. (DHS-10)

DICKSON is a single vertical dial hanging balance where the load is supported on two coil springs. These coil springs which are fitted with zinc alloy rate adjusters are made from suitable spring steel.

The linear extension of the springs is translated into rotary motion of the indicator by a precision rack and pinion.

These are case hardened for long accurate life. The pinion is mounted in plain brass bearings, with exception of the bloodweigher which has a precision ball race.

The upper ends of both main coil springs can be raised or lowered by means of an externally accessible, knurled screw to allow the indicator to be set to zero. This allows approximately $\pm 10\%$ adjustment.

The case unit is of cast aluminium and pressed steel and is finished in grey crackle paint, with exception of the blood weigher which is finished in white paint. The dial cover is of clear acrylic. All appropriate metal parts are zinc plated and full chromate passivated for maximum corrosion resistance.



**新發興機械(馬)有限公司
Sin Huat Hin Machinery (M) Sdn. Bhd.**

241232-A

www.shhmach.com

sinhuathin@shhmach.com

Since 1968

High Quality