

RETAIL WEIGHING SOLUTION™



54 direct PLU keys

LP-1 SERIES

Label Printing Scale

LP-1 series design to fit in hyper market, butcher shop and small retail stores.

Free label format is supported to various printing style.

LP-1 series is designed to provide large memory PLUs for per items for printing.

- Up to 4,000 PLUs, 1,000 messages of each 400 characters
- Pre-pack mode for automatic weighing and labeling
- Printing detail report for each item
- High speed thermal printer.



CAS

LP-1 SERIES | Label Printing Scale

TOTAL WEIGHING SOLUTION™

SPECIFICATIONS

Model	LP-1		
Max.capacity (kg)	6	15	30
Readability (g)	2	5	10
External resolution	1/3,000		
Display digit	5/6/7 (Weight / Unit price / Total price)		
Display type	3 VFD displays		
Printing speed	100mm/sec		
Label size	58 x 30mm ~ 58 x 100mm		
Operating temperature	-10℃~ 40℃		
Power	AC 100 ~ 240V, 50/60Hz		
Platter size (mm)	400(W) x 245(D)		
Dimensions (mm)	Standard type : 410(W) x 430(D) x 197(H) Pole type : 410(W) x 483(D) x 585(H)		
Product weight (kg)	Standard type : 9.5 Pole type : 10.6		

FEATURES

- Up to 4,000 PLUs & 1,000 messages
- Up to 400 characters per each ingredient
- 54 preset keys for frequent transaction items
- PLU data items
 - Commodity name, Message item No., Tare weight, Unit price, Group code
- Printing items
 - Commodity name, Message, packed-on data, Sell-by date
 - Unit price, Weight, Total price, Store name & address, Serial No., Time, PLU No., Group code
- Easy programming with a wide keyboard
- Pre-pack mode for automatic weighing and labeling
- Printing detail report for each item
- Free format label design (31 fixed & 6 free designed formats)
- Bar code : EAN8, 12of5, UPC13A, UPC13A2, UPC13A5, EAN8A2, EAN8A5, EAN13, EAN13A2, EAN13A5
- High speed & low noise thermal printer

OPTIONS

- Communication network (TCP/IP)
- Pole display
- PC manager program
- Large tray



Pole display

新發興機械(馬)有限公司
Sin Huat Hin Machinery (M) Sdn. Bhd.

241232-A
HQ: -
697, Tmn Chi Aik, Jln Tun Dr. Ismail, 70200 Seremban, NSDK.
T: +(6) 06 763 3333 F: +(6) 06 765 3334 E: sinhuathin@shhmach.com
KL Branch Office: -
B1-00-20, Jln SR 1/9, Tmn Serdang Raya, Section 9, 43300 Seri Kembangan, Selangor.
T: +(6) 03 8945 2202 F: +(6) 03 8948 3151 E: sinhuathinkl@shhmach.com

Visit us at www.shhmach.com

Label formats

- LP-1 series provides various label formats to customers. Operator can print out up to 400 letters.

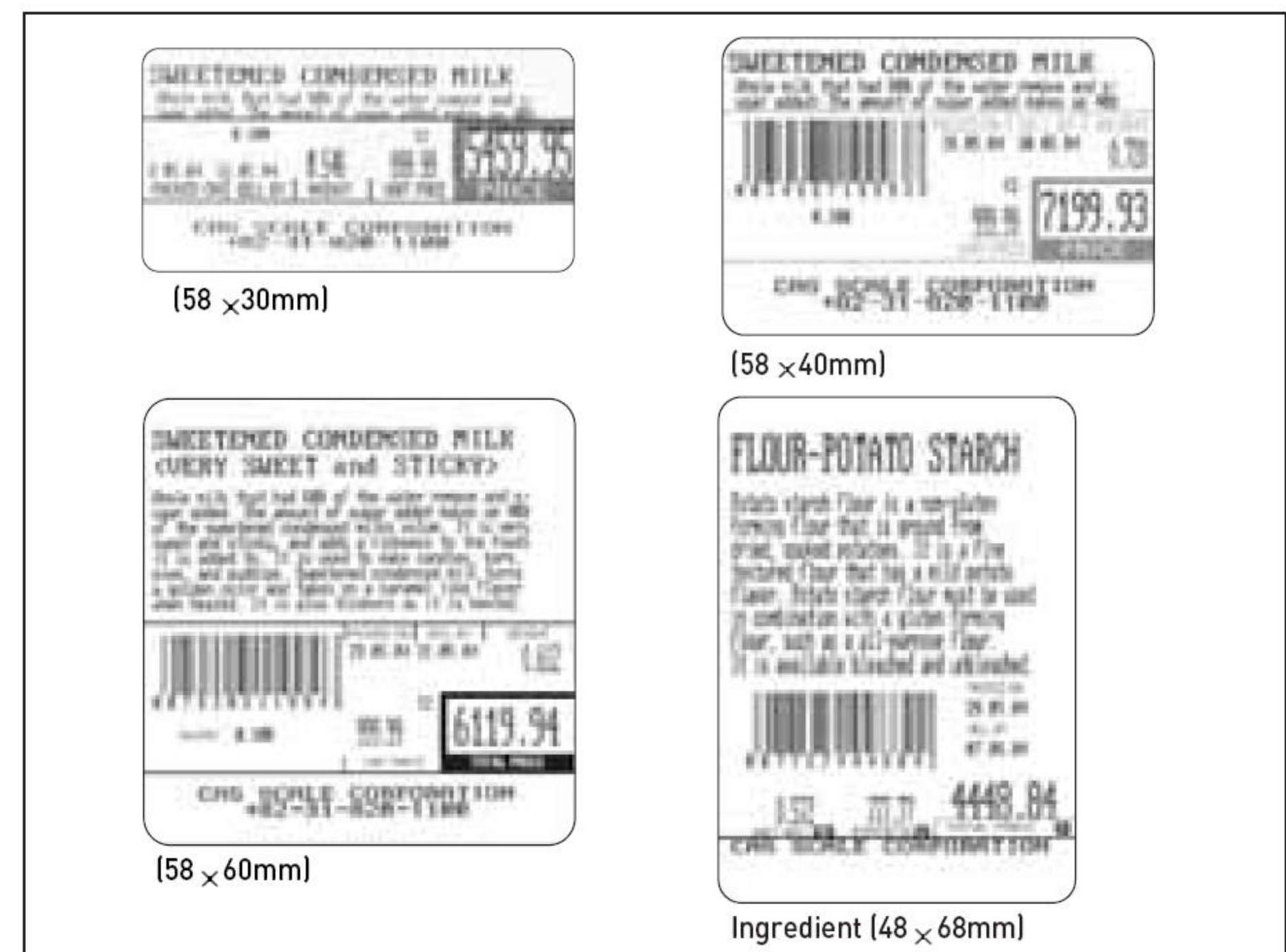

(50% Of Original Size)

PC manager program

- LP-1 series allows operators to print image and design high-quality labels. In addition, through using PC manager program, operators are able to print out various types of barcode format and 6 free format labels.



PLU editor

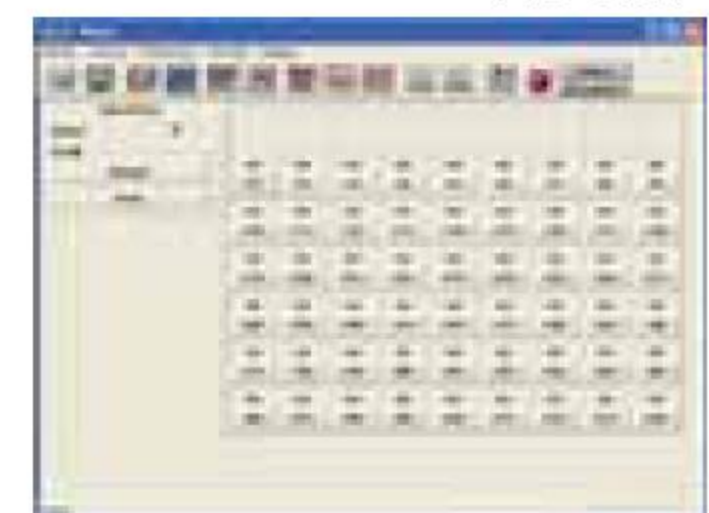

Keypad editor



Label editor

DIMENSIONS

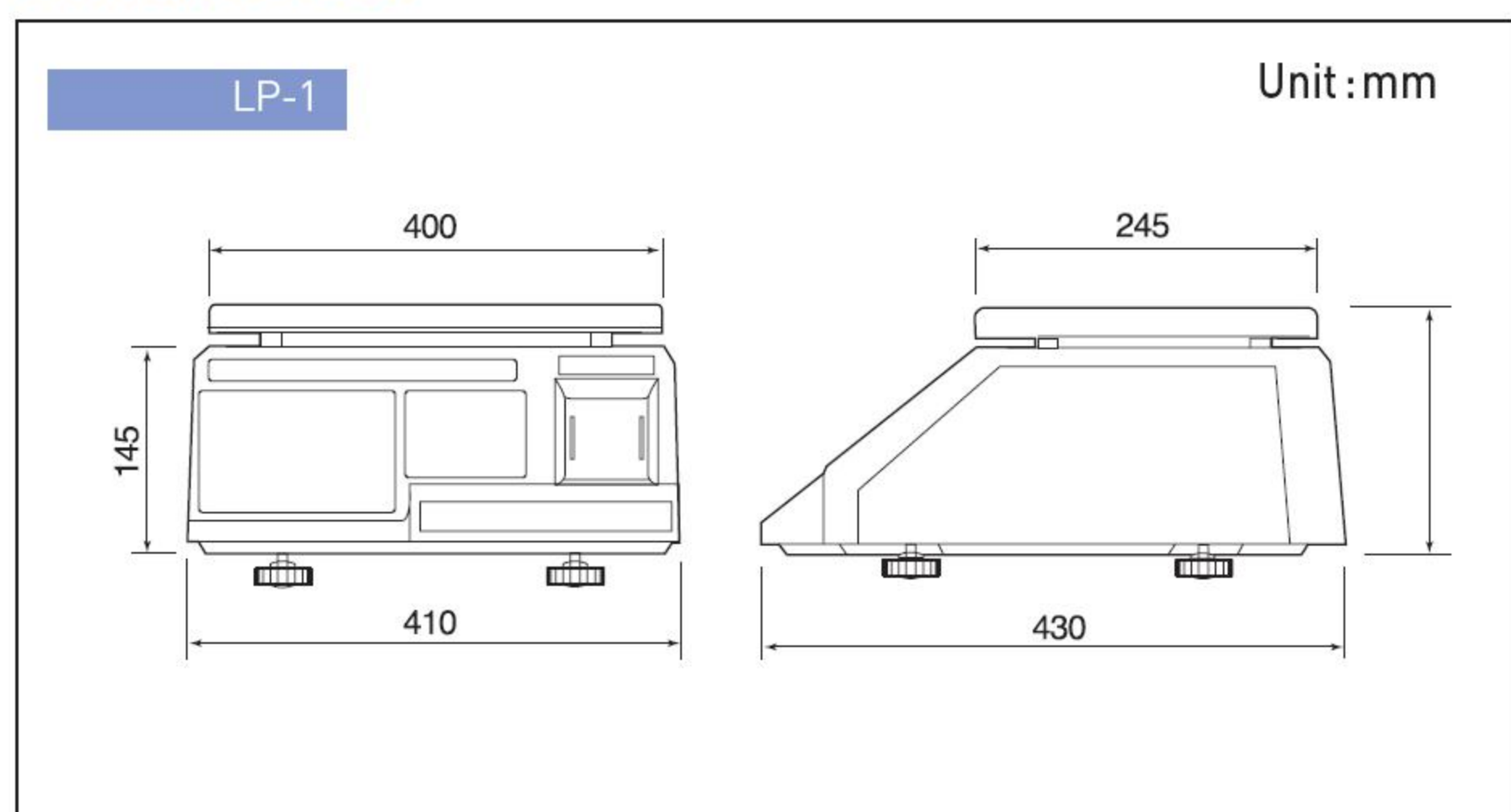

Unit : mm

Specifications are subject to change for improvement without prior notice.

C-808002